

### Impeller type heat and heat/cooling energy meters

WFx5



**Electronic, mains-independent impeller type heat meters with optional cooling range to acquire heat or cooling energy consumption on autonomous heating, cooling or solar plants.**

- Nominal flow 0.6 m<sup>3</sup>/h, 1.5 m<sup>3</sup>/h or 2.5 m<sup>3</sup>/h
- Optional communications add-on module
- Upstream or downstream setting paths are not required
- Can be installed horizontally or vertically
- Setting of device-specific parameters on the meter itself in the field via buttons or operating and parameter setting software ACT50
- Optical interface
- Self diagnostics

## Use

The impeller type heat and cooling energy meter is of compact design and used for the physically accurate acquisition of energy consumption.

The meter consists of a flow measuring section, 2 ready connected temperature sensors, and an electronic unit which calculates energy consumption from the flow and the temperature differential. The device is available for heat, combined heat/cooling, or solar metering.

It is primarily used on plants with central production of heat or cooling energy, where the heating or cooling energy is individually supplied in lines to multiple consumers, for example in:

- Multi-family homes
- Office and administrative buildings

Typical users:

- Service and billing providers
- Housing industry and housing cooperatives
- Building service companies and real estate agencies

### Restrictions

The meter's temperature sensors and battery cannot be replaced.

The meter is not approved for use in drinking water systems.

### RF sets

Available RF heating and RF heating/cooling meter sets are available in data sheet A6V11259309.

The data sheet can be downloaded at <http://siemens.com/bt/download>.

## Functions

### Meter design

The meter comprises a flow and return temperature sensor and flow sensor installed in a hot water or cooling water circuit. A processor continuously calculates the temperature differential of flow and return and multiplies the value by the flow rate. The result (the current heat or cooling energy output) is added up, displayed, and forwarded via radio or cable to a data processing system using an optional add-on module. A long-life battery powers the processor for up to 10 years.

### Impeller type measuring principle

The meter's flow sensor operates in accordance with the single-jet impeller sensor principle. The water flow hits the impeller radially. The impeller's speed is scanned electronically. Incorrect direction of flow is detected and indicated by an error message on the display.

### Calculation of heat or cooling energy consumption

Using the acquired temperature differential of flow and return, the measured flow rate as well as the calculated thermal coefficient, the quantity of heat or cooling energy is shown on the display in physical units (kWh or MWh/MJ or GJ) following an internal calculation process. To increase measuring accuracy, the density and enthalpy values are determined for every measurement and included in the calculation.

**Processor**

The same standard processor with a built-in service unit is used for all flow rates.

**Infrared interface**

Consumption meters with optical close-range interface must be read out on site. The meter is read out and configured with the WFZ.IRDA-USB optical reading head and the associated ACT50 software.

**Module interface**

Each meter is equipped with a module interface. The meter can be read out from a remote location by installing the optional add-on module.

**Tampering**

The meter is protected by a factory-fitted seal.

**Function check**

The temperature is acquired at 36-second intervals (or optional, every 6 seconds). The flow is acquired continuously. The amount of energy supplied is displayed in real time. Any errors are immediately displayed.

**Screwed type meter**  
**Pressure loss characteristics**  
**0.6 m<sup>3</sup>/h,**  
**110 mm**

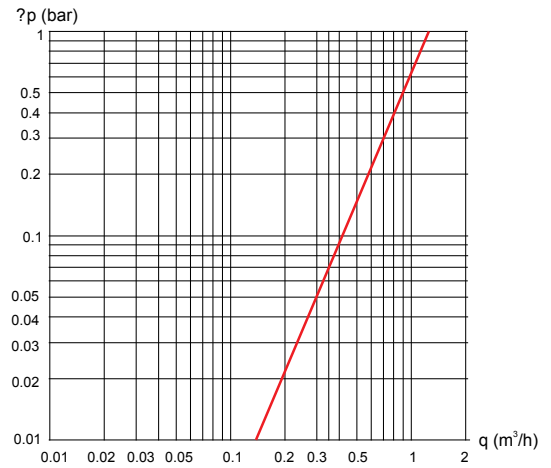

**Screwed type meter**  
**Pressure loss characteristics**  
**1.5 m<sup>3</sup>/h,**  
**80 mm and 110 mm**

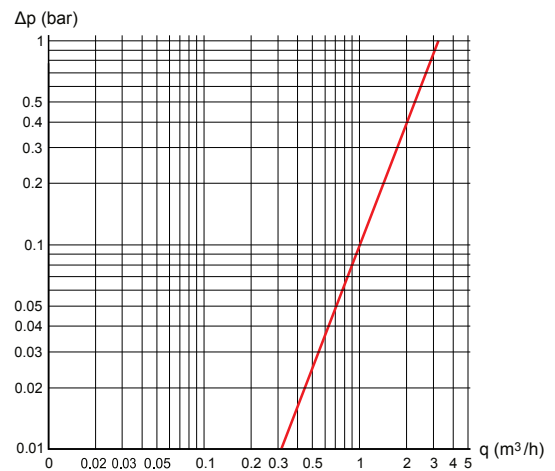

**Screwed type meter**  
**Pressure loss characteristics**  
**2.5 m<sup>3</sup>/h,**  
**130 mm**

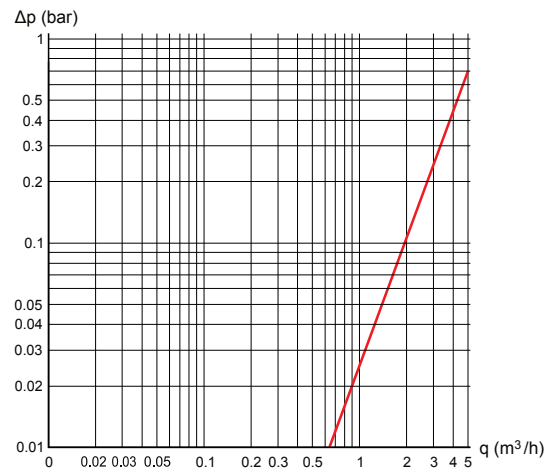

**Standard parameters**

The unit comes programmed as follows:

- Due date: 31.12.
- Display of consumption in kWh

All display levels are shown.

The heating or cooling energy consumption values are continuously cumulated. The state is stored at 12 am on the due date.

Every time current and annual consumption is stored, the heat meter calculates a checksum. This can be read out together with the due date value and checked in the billing program.

This detects incorrect read outs of the display. The stored due date remains in place for one year.

## Parameter settings via PC

The following parameters are read out or set with the ACT50 software via the optical close-range interface:

### General

- Serial number
- Mounting place
- Installation location
- Firmware version
- Medium
- Date of commissioning
- Battery life
- Stock number
- Heat carrier
- Error date
- Error code

### Device information

- Current temperature (return)
- Current temperature (flow)
- Current temperature (difference)
- Current energy flow
- Current flow rate
- Total flow rate
- Pulse value
- Device name

### Meter states

- Current meter state
- Last due date
- Meter state on last due date
- Next due date
- Supply low:
  - Maximum temperature
  - Date of maximum temperature
  - Duration of upper deviations
- Return flow:
  - Maximum temperature
  - Date of maximum temperature
  - Duration of upper deviations
- Flow:
  - Maximum flow rate
  - Date of maximum flow rate
  - Duration of upper deviations
- Statistical values:
  - 15 monthly values with date

In addition for devices with solar modification:

- Ratio of glycol or brine

### Parameter settings via the meter

The following parameters can be entered directly on the meter using both operating buttons:

- Next due date
- Display of kWh or MWh/MJ or GJ
- Selection of levels to be displayed
- Display of meter read outs with or without checksum

In addition for devices with solar modification:

- Ratio of glycol on solar plants

### Communication

The meter is supplied with an optical close-range interface.

### Add-on modules



The following external communication modules are available:

- M-bus module WFZ51
- RF add-on module WFZ662

The ACT50 software can be used to configure the RF add-on module.

### M-bus module WFZ51



### Function description

The M-bus module (WFZ51) enables the meter to communicate with an M-bus central communication unit to transmit the measured values. The module can be read out 24/7 as often as you want via M-bus. The heat meter measured values are read out and saved from the module at 10-minute intervals.

### Readout parameters

The following parameters are read out via the M-bus interface:

- Device number (8 digits)
- Medium/software version
- Time/Date
- Error state (readout 5 or 45 times a day)
- Error date

- Current consumption values (heat or cooling energy, volume)
- Due date
- Due date value (heating or cooling energy)

The following data queried via application selection (per EN 13757-3 or supplier-specific) as an option:

- 13 monthly values (heating or cooling energy)
- Flow rate
- Power
- Energy
- Flow/return temperature

#### **RF add-on module WFZ662**



The meters are read out remotely using the RF add-on module. The module sends out parallel AMR and walk-by data telegrams.

The AMR telegrams are automatically collected and saved by a network node WTT561...

The walk-by telegram can be collected during a walk by using the mobile data logger WTT665... The customer can remotely read out all plant consumption data.

#### **Readout parameters**

The following parameters can be read out and/or configured using the ACT50 via the IrDA interface:

Read out only:

General

- Serial number
- Mounting place
- SW version
- Date of commissioning
- Battery life
- Stock number
- Device date
- Error date
- Error code

Device information

- Device name/password

Meter states

- Current meter state
- Last due date
- Meter state on last due date
- Next due date

Statistical values

- 13 monthly values

#### RF settings

- RF mode
- RF system
- Walk-by readout type
- Walk-by transmission delay
- Walk-by transmission timeframe
- Walk-by transmission-free days

#### Configuration:

##### General

- Mounting place

##### Due date

- Next due date

##### Device information

- Device name
- Device password

#### RF settings

- RF mode
- RF system
- Walk-by readout type (S-mode only)
- Walk-by transmission delay (S-mode only)
- Walk-by transmission timeframe
- Walk-by transmission-free days (S-mode only)

#### RF features in S-mode

RF add-on module in S-mode have the following features:		
RF system	Parallel transmission of data telegrams	<ul style="list-style-type: none"><li>• AMR</li><li>• Walk-by</li></ul>
Transmission delay (Offset)	Time delay for sending out telegrams after the due date Time delay for sending out telegrams after the start of the month in days (Default = 0 days)	
Transmission-free days	A maximum of 2 days of the week can be defined as transmission-free days. At least 1 day of the week must be set (Default = Sunday)	

Transmission response		
AMR telegrams	Every 4 hours, 24 hours a day, 365 days a year Data telegrams with the current consumption value and due date value as well as monthly telegram with consumption value at the end of the last month	
Walk-by telegrams	Every 128 seconds, 10 hours a day (from 8:00 am to 6:00 pm)	
	Readout type	Monthly: 4 readout days as of the first of each month Annually: 48 readout days, once a year by due date



Transmission response		
	Transmission-free days	Monthly: Saturday and Sunday Annually: Sunday
	Current consumption value, due date value, due date as well as end of month values for the last 13 months	

### RF features in C-mode

RF add-on modules in C-mode have the following features:		
RF system	Parallel transmission of data telegrams	<ul style="list-style-type: none"> <li>• AMR</li> <li>• Walk-by</li> </ul>
	Increase RF output (typically 10 dBm)	
AMR telegrams	Every 7.5 hours, 24 hours a day, 365 days a year Data telegrams with current consumption value, due date value, and consumption value at the end of the last month as well as status telegrams	
Walk-by telegrams	Every 112 seconds, 10 hours a day (from 8:00 am to 6:00 pm) 365 days a year	
	Current consumption value, due date value, due date as well as end of month values for the last 13 months	

### Change of mode

You can switch between S-mode and C-mode any time with the help of the ACT50 (V2.6.0 or higher) and the infrared read head WFZ.IRDA-USB.

### Display:

#### Processor type

The LCD displays meter states, display units, and consumption values on multiple levels. The meter has 2 buttons to switch between the individual display steps and levels.



1 Button for navigating on a level

2 Button for changing a level

### Operating

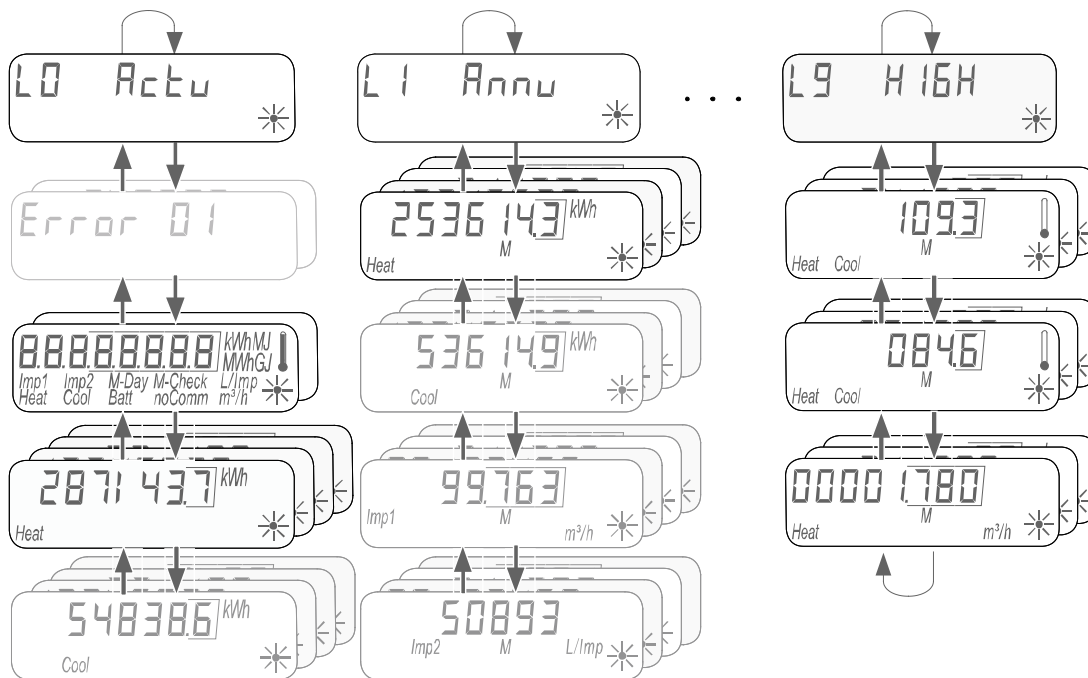

### Quick reading mode

The meter's display is in sleep mode ☾ and only activates when a button is pressed. A single short press of a button repeats the quick read loop 10x. At the end of 10 repetitions, the display returns to sleep mode ☾.

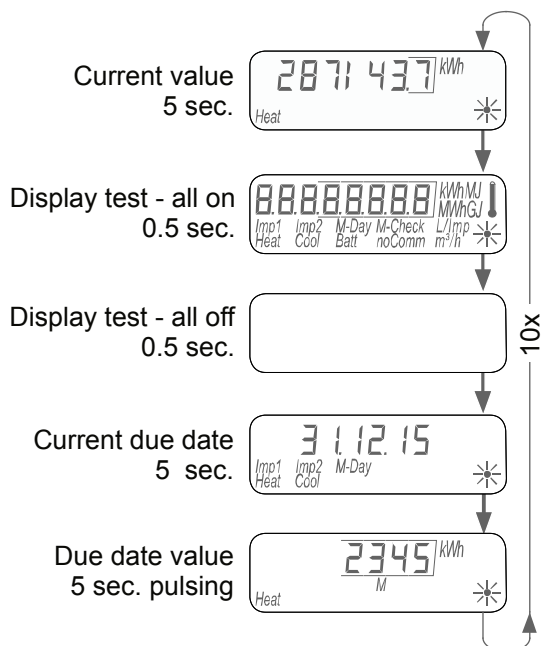

The quick read loop can be cancelled at any time by pressing a button > 3 s. The display automatically goes to the standard display levels.

## Error messages

For a serious fault, the error code and error date is displayed in front of the meter state display.

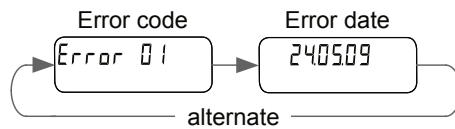

The meter state display displays "incorrect flow direction" if it determines that the flow direction is wrong:



## Display levels

The following display levels are available:

- Standard levels:
  - L0 Current consumption values
  - L1 Annual consumption values
- The levels can be deactivated individually:
  - L2 Current values
  - L3 Parameters
  - L4 Connections
  - L5 Monthly values heat
  - L6 Monthly values cooling
  - L9 Maximum values

If an error message is pending, it is logged with the respective error code and the date the error occurred and shown on the display (alternating).

Level L0  
Current  
consumption values

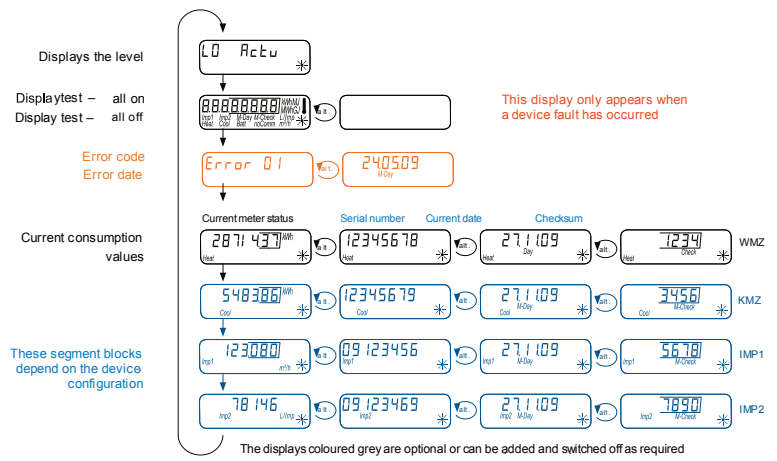

Level L1  
Consumption values at  
the  
Due date

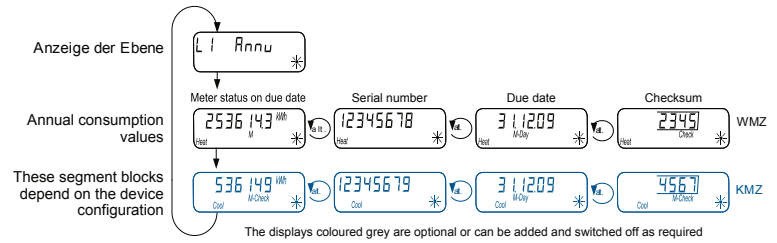

Level L2  
Current values

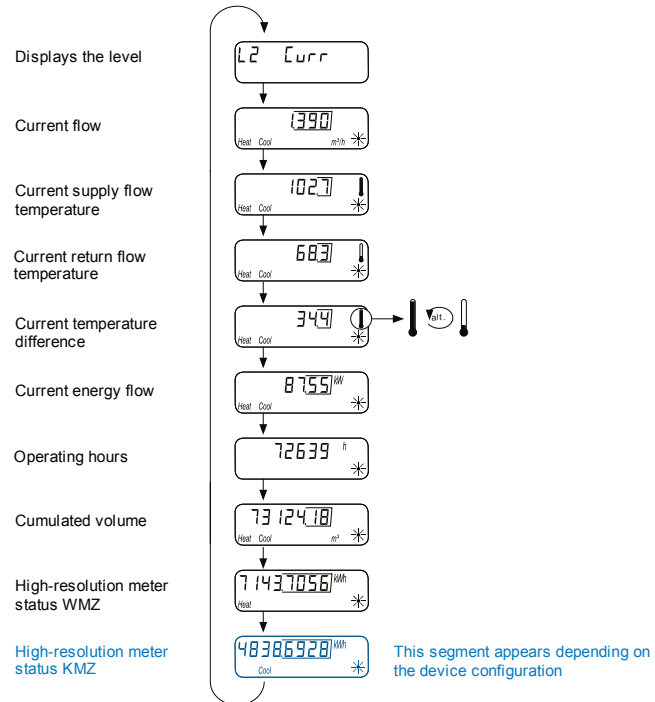

Level L3  
Parameters

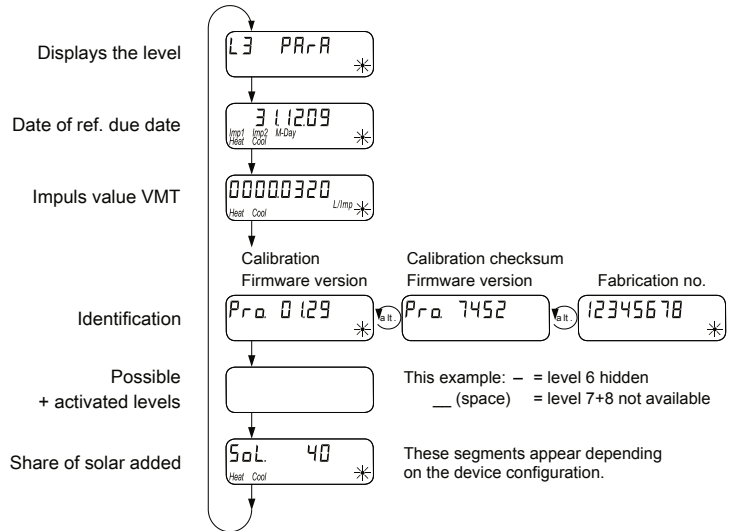

Level L4  
Connections

These segment blocks appear depending on the meter's configuration

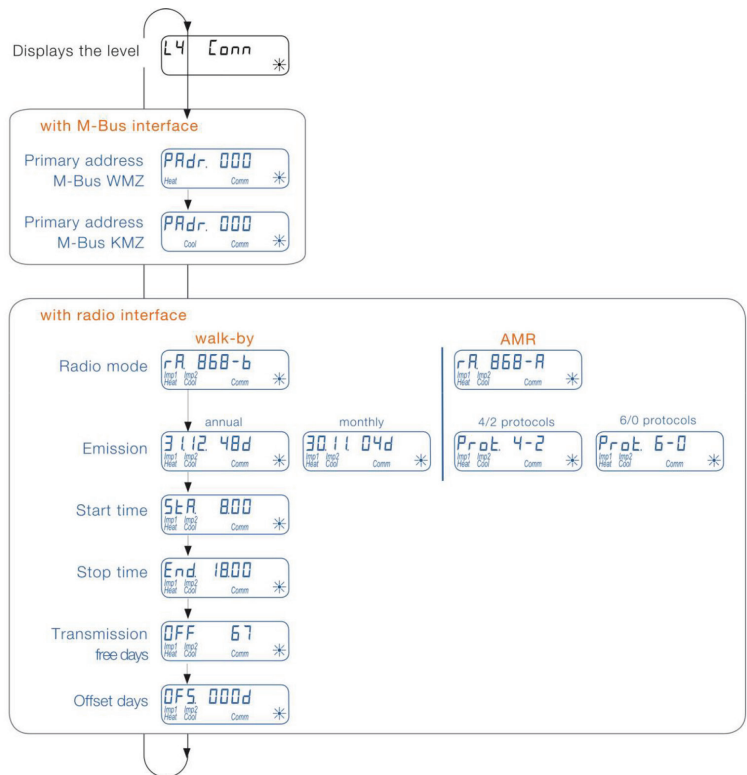

Level L5  
Monthly values heat

This level is displayed only when the meter is configured for metering heat.

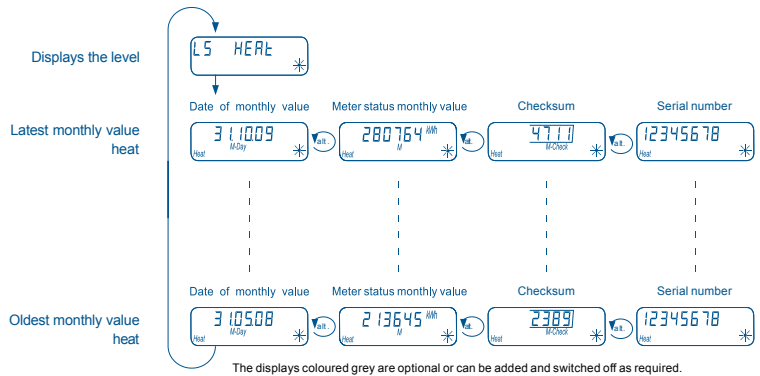

**Level L6**  
Monthly values cooling energy

This level is displayed only when the meter is configured for metering cooling energy.

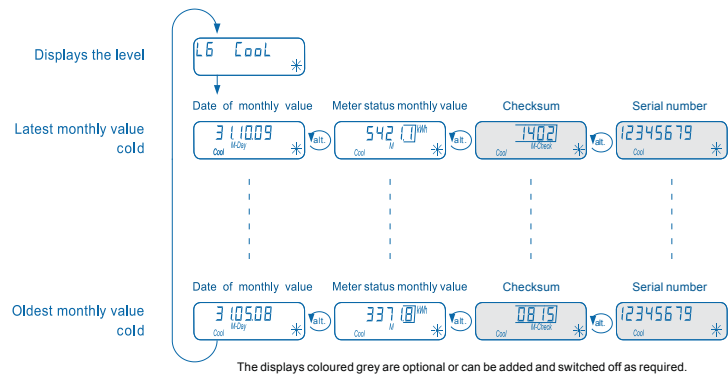

**Level L9**  
Maximum values

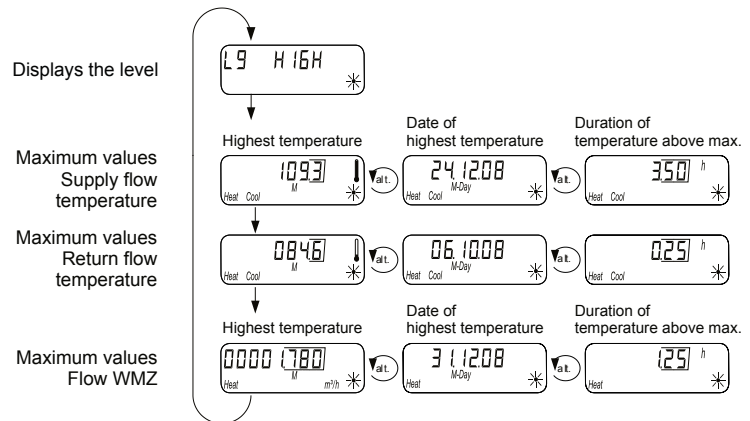



**Error messages**

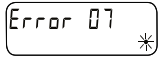
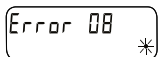
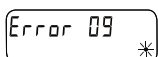

Indication of errors	Description of error	Measures/notes
Error 01 *	Hardware error or damaged software	Check flow sensor, connecting cable and processors for signs of external damage Exchange the device
Error 03 *	The add-on module was previously paired with another measuring instrument The module possesses measured data from another meter	Backup data as it will be overwritten in the near future Press any button to confirm deletion of the display The new add-on module is accepted after deletion
Error 04 *	Low power (RF add-on module)	Maximum operating period has expired Exchange the add-on module
Error 05 *	The add-on module does not initialize (time is incorrect)	Exchange the add-on module
Error 06 *	Flow sensor is broken	Check the temperature sensor and wires for mechanical damage Exchange the device

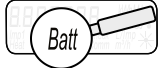



Indication of errors	Description of error	Measures/notes
	Flow sensor short circuit	Check the temperature sensor and wires for mechanical damage Exchange the device
	Return sensor is broken	Check the temperature sensor and wires for mechanical damage Exchange the device
	Return sensor short circuit	Check the temperature sensor and wires for mechanical damage Exchange the device

### Operating state display

Display	Description	Measures/notes
	Exceeds communications credit IrDA	Eliminated after credit period expires (Irda = current month).
	Operating time has expired	Device must be replaced or exchange the battery.
Comply with all national and country-specific regulations!		
	Flow direction incorrect	Check installation (note arrow on the flow sensor) Check piping Check circulating pumps and thermostats for proper operation
	Temperature sensors are switched around or incorrectly mounted	Check whether the flow sensor was mounted in the correct line or check the installation type for the temperature sensor

### Status display

Display	Description	
	The displayed data applies to:	
	Heat = Wärme	Imp1 = Pulse input 1
	Cool = Kälte	Imp2 = Pulse 2
	(empty) = Displayed value is the current value	
	M (Memory) = Value at a monthly or due date	
	Displayed value is date:	
	Day = Current date	
	M-Day = Date applies to saved yearly or monthly value	

Display	Description
	Displayed value is a checksum: Check = Checksum refers to a current consumption value M-Check = Checksum applies to a saved yearly or monthly value
	Current flow available No energy metering -> No temperature difference
	Current flow available Energy metering
	IrDA communication is just active

### Processor

The meter's processor is designed as follows:

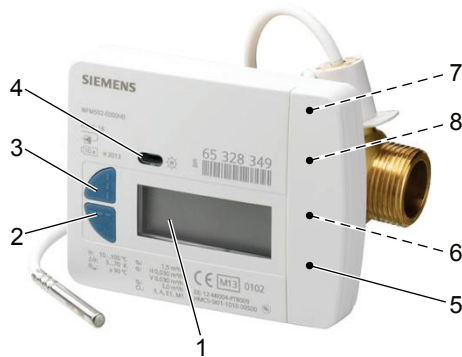

- |                                   |  |
|-----------------------------------|--|
| 1 LCD                             | 5 Interface cover  |
| 2 Button to change between levels | 6 Module interface   |
| 3 Button to navigate on a level   | 7 Fixing holes for external add-on modules                   |
| 4 IrDA interface                  | 8 User protection and sockets for external cable connections |

The processor's ambient temperature cannot exceed 55 °C. Avoid exposure to direct sunlight.

Depending on the version (compact or removable meter), the processor can be removed from the flow measuring section to be fitted on the wall with the mounting bracket at a distance of 40 cm.

### Add-on modules

The external add-on module (WFZ..) can be fitted to any meter.

Proceed as follows:

- a) Remove the interface cover from the heat meter
- b) Plug in the add-on module and secure it

Shortly after fitting, the add-on module identifies automatically the type of meter and makes the required alignment (series number, monthly values, due day, current value and type of medium).



### Wireless meters

ACT50 is used to configure the wireless modules.

Wireless operation is activated via the WFZ-PS radio telegram tool or the ACT50 software.

### Wired meters

Since the M-bus module adopts all parameters from the meter, only the primary address can be configured via the M-bus system.

The power required for operation is supplied by the M-bus system, but the module is equipped with a battery. It powers the module when there is no power available from the M-bus.

The modules do not affect the acquisition of consumption data and, for this reason, can be retrofitted at any time without damaging the seal.

### Sealing

After mounting the meter, all components must be sealed to prevent tampering (observe national regulations):

- The flow measuring section with its fitting (inlet)
- The flow temperature sensor with the ball valve or the immersion pocket, the immersion pocket with the pipe and, if required,
- The module with the processor

## Type summary

Features of the impeller type meters listed below:

Mounting location	Return
Design	Processor combined with flow measuring section
Rated pressure	PN 16
Sensor mounting	Return sensor, integrated in the flow measuring section
Temperature sensor type	Pt1000, Ø 5.0 mm, length 45 mm
Temperature sensor cable length	1.5 m
Communication	IrDA interface
Threshold value for:	
• Acquisition of heating	1.0 K
• Acquisition of cooling energy	0.2 K
Due date	31.12
Display	kWh

### Heat meter

Options	Order number	Type
0.6 m <sup>3</sup> /h, mounting length 110 mm, connecting thread G ¾"	S55561-F177	WFM501-E000H0
1.5 m <sup>3</sup> /h, mounting length 110 mm, connecting thread G ¾"	S55561-F178	WFM502-E000H0
2.5 m <sup>3</sup> /h, mounting length 130 mm, connecting thread G 1"	S55561-F179	WFM503-J000H0

Combined heat/cooling energy meters and additional types available on request.

#### Add-on modules

Designation	Order number	Type
M-bus module	S55563-F131	WFZ51
RF add-on module	S55563-F153	WFZ662

#### Installation sets, ball valves

Designation	Order number	Type
Installation set Rp ½", consisting of: 2 ball valves Rp ½" with coupling nut G ¾" and flat gasket 2 mm, ¾" 1 ball valve Rp ½" with M10x1 mm for fitting temperature sensor Ø5.0x45 mm	JXF:HMXIK001-001	HMXIK001-001
Installation set Rp ¾", consisting of: 2 ball valves Rp ¾" with coupling nut G ¾" and flat gasket 2 mm, ¾" 1 ball valve Rp ¾" with M10x1 mm for fitting temperature sensor Ø5.0x45 mm	JXF:HMXIK001-002	HMXIK001-002
Installation set Rp 1", consisting of: 2 ball valves Rp 1" with coupling nut G ¾" and flat gasket 2 mm, ¾" 1 ball valve Rp 1" with M10x1 mm for fitting temperature sensor Ø5.0x45 mm	JXF:HMXIK001-003	HMXIK001-003
Installation set Rp 1", consisting of: 2 ball valves Rp 1" with coupling nut G 1" and flat gasket 2 mm, 1" 1 ball valve Rp 1" with M10x1 mm for fitting temperature sensor Ø5.0x45 mm	JXF:HMXIK001-004	HMXIK001-004
Installation set Rp ¾", consisting of: 2 ball valves Rp ¾" with coupling nut G 1" and flat gasket 2 mm, 1" 1 ball valve Rp 1" with M10x1 mm for fitting temperature sensor Ø5.0x45 mm	JXF:HMXIK001-005	HMXIK001-005

## Installation sets fittings

Designation	Order number	Type
<p>Installation set Rp ½", consisting of:</p> <p>2 fittings Rp½" with coupling nut G¾" and flat gasket 2 mm, ¾"</p> <p>1 ball valve Rp ½" with M10x1 mm for fitting temperature sensor Ø5.0x45 mm</p>	JXF:HMXIK002-001	HMXIK002-001
<p>Installation set Rp ¾", consisting of:</p> <p>2 fittings Rp ¾" with coupling nut G ¾" and flat gasket 2 mm, ¾"</p> <p>1 ball valve Rp ¾" with M10x1 mm for fitting temperature sensor Ø5.0x45 mm</p>	JXF:HMXIK002-002	HMXIK002-002
<p>Installation set Rp 1", consisting of:</p> <p>2 fittings Rp 1" with coupling nut G ¾" and flat gasket 2 mm, ¾"</p> <p>1 ball valve Rp 1" with M10x1 mm for fitting temperature sensor Ø5.0x45 mm</p>	JXF:HMXIK002-003	HMXIK002-003
<p>Installation set Rp 1", consisting of:</p> <p>2 fittings Rp 1" with coupling nut G 1" and flat gasket 2 mm, 1"</p> <p>1 ball valve Rp 1" with M10x1 mm for fitting temperature sensor Ø5.0x45 mm</p>	JXF:HMXIK002-004	HMXIK002-004
<p>Installation set Rp ¾", consisting of:</p> <p>2 fittings Rp ¾" with coupling nut G 1" and flat gasket 2 mm, 1"</p> <p>1 ball valve Rp 1" with M10x1 mm for fitting temperature sensor Ø5.0x45 mm</p>	JXF:HMXIK002-005	HMXIK002-005

## Spacers

Designation	Order number	Type
Spacer G ¾", Length 80 mm	JXF:FKM0070	FKM0070
Spacer G ¾", Length 110 mm	JXF:FKM0074	FKM0074
Spacer G 1", Length 130 mm	JXF:FKM0075	FKM0075

## Extensions

Designation	Order number	Type
Adapter set G ¾" to 1", consisting of: 2 adapter pieces G ¾" to G 1" 2 flat gaskets 2 mm, 1"	JXF:HMXIK003-001	HMXIK003-001
Extension set G ¾" x G 1", consisting of: 2 extension set from 110 mm, G ¾" to 130 mm G 1" 2 flat gaskets 2 mm, 1"	JXF:HMXIK003-002	HMXIK003-002
Extension set 110 mm G ¾" to 130 mm G ¾", consisting of: 1 extension 27 mm 2 flat gaskets 2 mm, ¾" 1 gasket made of copper ¾" x 1.5 mm	JXF:HMXIK003-003	HMXIK003-003
Extension set 110 mm G ¾" to 165 mm G ¾", consisting of: 1 extension 27 mm 1 extension 42 mm 2 flat gaskets 2 mm, ¾" 1 gasket made of copper ¾" x 1.5 mm	JXF:HMXIK003-004	HMXIK003-004
Extension set 110 mm G ¾" to 190 mm G ¾", consisting of: 2 extension set from 110 mm G ¾" to 190 mm G 1" 2 flat gaskets 2 mm, 1" 1 gasket made of copper ¾" x 1.5 mm	JXF:HMXIK003-005	HMXIK003-005

## Fittings

Designation	Order number	Type
Fittings R ½" x G ¾", without gasket	JXF:FKM0018	FKM0018
Fittings R ¾" x G ¾", without gasket	JXF:FKM0019	FKM0019
Fittings R 1" x G ¾", without gasket	JXF:FKM0020	FKM0020
Fittings R ¾" x G 1", without gasket	JXF:FKM0021	FKM0021
Fittings R 1" x G 1", without gasket	JXF:FKM0022	FKM0022

## Ball valves

Designation	Order number	Type
Ball valve Rp ½" with temperature sensor fitting M10x1 mm for sensor Ø5.0x45 mm	JXF:FKM0023	FKM0023
Ball valve Rp ¾" with temperature sensor fitting M10x1 mm for sensor Ø5.0x45 mm	JXF:FKM0024	FKM0024
Ball valve Rp 1" with temperature sensor fitting M10x1 mm for sensor Ø5.0x45 mm	JXF:FKM0025	FKM0025
Ball valve Rp ½" with coupling nut G ¾" and temperature sensor fitting M10x1 mm for Sensor Ø5.0x45 mm, without gasket	JXF:FKM0076	FKM0076
Ball valve Rp ½" with coupling nut G ¾", without gasket	JXF:FKM0027	FKM0027
Ball valve Rp 1" with coupling nut G ¾", without gasket	JXF:FKM0029	FKM0029
Ball valve Rp ¾" with coupling nut G 1", without gasket	JXF:FKM0030	FKM0030
Ball valve Rp 1" with coupling nut G 1", without gasket	JXF:FKM0031	FKM0031

## Accessories

Designation	Order number	Type
Flat gasket ¾", thickness 2 mm	JXF:FKS0005	FKS0005
Flat gasket 1", thickness 2 mm	JXF:FKS0006	FKS0006
T-piece R ½" x G ¼"	JXF:FKM0035	FKM0035
T-piece R ¾" x G ¼"	JXF:FKM0036	FKM0036
T-piece R 1" x G ¼"	JXF:FKM0037	FKM0037
Immersion sleeve G ¼" for sensor Ø5.0 x 45 mm, without gasket	JXF:FKM0038	FKM0038
Immersion sleeve M10x1 mm for sensor Ø5.0x45 mm, without gasket	JXF:FKM0051	FKM0051
Immersion sleeve G ¼" for sensor Ø5.2 mm, without gasket	JXF:FKM0039	FKM0039
Immersion sleeve M10x1 mm for sensor Ø5.2 mm, without gasket	JXF:FKM0052	FKM0052
Temperature sensor sleeve G ¼" for sensor Ø5.0x45 mm and Ø5.2x45 mm	JXF:FKM0049	FKM0049
Temperature sensor sleeve M10x1 mm for sensor Ø5.0x45 mm and Ø5.2x 45 mm	JXF:FKM0050	FKM0050
Temperature sensor screwed made of brass for sensor Ø5.0 mm and Ø5.2 mm, directly or indirectly immersed	JXF:HMXIK004-001	HMXIK004-001
Wall bracket for WFx5 Heat meter	JXF:HMRİK001-001	HMRİK001-001
Seal, wire length 250 mm	JXF:FNS0001	FNS0001

## Software

Designation	Order number	Type
Infrared read head with USB interface	JXF:WFZ.IRDA-USB	WFZ.IRDA-USB
Parameterization and diagnostic software	JXF:ACT50	ACT50
Radio telegram tool	JXF:WFZ.PS	WFZ.PS

## Ordering

When ordering, please specify the quantity, designation, type, and order number.

Designation	Order number	Type
Impeller heat and heat/ cooling energy meter	See "Type overview"	WFx5..

## Scope of delivery

The meters come complete with operating and installation instructions in different languages as well as all required mounting materials (gaskets, seals, etc.).

The RF add-on module is delivered in packages of 10 items (1 packaging unit).

Installation instructions are supplied with each packaging unit in various languages as well as cable seals and mounting screws.

## Languages

The Installation Instructions are supplied in the following languages:

Bulgarian, German, English, Finnish, French, Greek, Italian, Croatian, Lithuanian, Dutch, Norwegian, Polish, Rumanian, Slovakian, Slovenian, Spanish, Czech, Turkish, and Hungarian.

## Notes

### Installation

#### Flow measuring section

The meter can be mounted in any position (exception: installation above head is not allowed). The installation location (return or flow) is based on meter type. Inlet or outlet settling paths are not required. If the meter is installed in the common return of 2 heating circuits (e.g. space heating and DHW), the mounting location must be at an adequate distance from the T-piece (min. 10 x DN) to allow the different water temperatures to properly mix.

The system must be properly flushed before installing the meter.

Mount the flow measuring section between 2 shutoff valves with the arrow on the measuring section pointing in the direction of flow. The sensors must be mounted in the same water circuit as the flow measuring section (observe mixing). The sensors can be fitted in T-pieces, ball valves, direct immersed or in pockets (national regulations must be observed). In any case, the end of the sensors must extend to at least the pipe center. Temperature sensors and fittings must be sealed to prevent tampering.

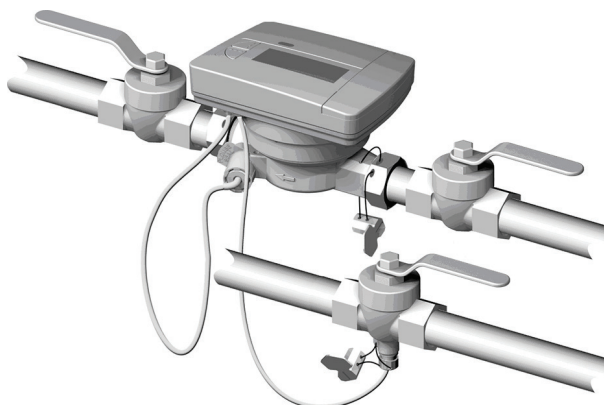

Mounting with ball valves

## Maintenance

---

The meters are maintenance-free. Comply with all national calibration regulations.

## Disposal

---



The device is considered an electronic device for disposal in accordance with the European Guidelines and may not be disposed of as domestic garbage.

- Dispose of the device through channels provided for this purpose.
- Comply with all local and currently applicable laws and regulations.
- Dispose of empty batteries in designated collection points.

## Warranty

Technical data on specific applications are valid only together with Siemens products listed in this data sheet. Siemens rejects any and all warranties in the event that third-party products are used.



**Processor**

Power supply	
Battery type	Lithium battery CR AA (cannot be replaced)
Battery power	3.0 V
Battery life	10 years with reserve

Function data	
Measuring range	15...105 °C
<ul style="list-style-type: none"> <li>Heat meter</li> <li>Heat meter with optional cooling range</li> </ul>	Cooling range: 0.2...24 °C
Range of temperature differential $\Delta\theta$	3...70 K
Temperature response threshold	1.0 K
<ul style="list-style-type: none"> <li>Heating</li> <li>Cooling</li> </ul>	0.2 K
Thermal coefficient	Shifting-compensated

Temperature sensor.	
Sensing element	Pt1000 per EN 60751
Technical design	Type DS (installed directly)
Diameter	Ø 5.0 x 45 mm (standard)
Cable length	1.5 m (standard) (3 m optional)

Display	
Display	8-digit LCD + pictograms
Energy display	kWh Optional: MWh/MJ/GJ

Communication	
Optical interface	Similar to EN 62056-21
<ul style="list-style-type: none"> <li>Basic design</li> <li>Protocol</li> </ul>	Similar to EN 13757-2/3

Flow measuring section Screw type meter						
Temperature range (national approvals may differ)	10...90 °C					
Maximum temperature $t_{max}$ .	90 °C					
Rated pressure	1.6 MPa (PN 16)					
Nominal flow $q_p$	m <sup>3</sup> /h	0,6	1,5	1,5	2,5	
Mounting length	mm	110	80	110	130	
PIN		G ¾ B"	G ¾ B"	G ¾ B"	G 1 B"	
Metrological class						
<ul style="list-style-type: none"> <li>Horizontal</li> <li>Vertical</li> </ul>		1:50 1:25	1:50 1:50	1:50 1:50	1:50 1:50	
Maximum flow $q_s$	m <sup>3</sup> /h	1,2	3,0	3,0	5,0	
Minimum flow $q_i$						
<ul style="list-style-type: none"> <li>Horizontal</li> <li>Vertical</li> </ul>	l/h	12 24	30 30	30 30	50 50	
Response threshold	l/h	3...4	4...5	4...5	6...7	

Flow measuring section Screw type meter					
Pressure loss at $q_p$					
• Mounting length 80 mm $\Delta p$	mbar		200		
• Mounting length 110 mm $\Delta p$	mbar	200		200	
• Mounting length 130 mm $\Delta p$	mbar				180
Flow rate at $\Delta p = 1$ bar, $k_v$	$m^3/h$	1,5	3,2	3,2	5,3
Mounting orientation	Horizontal/vertical				

## Communication

M-bus module WFZ51	
M-bus slave interface	As per EN 1434-3 and EN 13757-2/3
• Battery type	Lithium battery CR 2/3 AA
• Battery power	DC 3.0 V
• Standby current	$\leq 1.5$ mA
• Standard load	1.5 mA
• Address	Primary and secondary
• Baud rate	300 or 2,400 baud
• Polarity	Optional
• Galvanic isolation	Per module interface
• Cable length	2.95 m
• IP class	IP65
• Protection class	III

RF add-on module WFZ662	
• Battery type	Lithium battery CR 2/3 AA
• Battery power	DC 3.0 V
• Battery life	>11 years
• Frequency	S-mode: 868.3 $\pm$ 0.3 MHz; C-mode: 868.95 $\pm$ 0.25 MHz
• Standards	Data transmission per EN 13757-4
• Transmission power, typical	Max. 10 dBm
• IP class	IP65
• Protection class	III

Housing type	
Protection class	III
IP class	
• Processor	IP65
• Flow measuring section	IP65

Environmental conditions	Operation EN 60721-3-3	Transportation EN 60721-3-2	Storage EN 60721-3-1
Climatic conditions	3K5	2K3	1K3
Temperature	5...55 °C	-25...70 °C	-5...45 °C
Humidity	<93% r.h. at 25 °C (non-condensing)	<93% r.h. at 25 °C (non-condensing)	<93% r.h. at 25 °C (non-condensing)
Mechanical conditions	3M2	2M2	1M2
Max. altitude	Min. 700 hPa, corresponding to max. 2000 m above sea level		

<b>Standards, guidelines</b>	
EU Conformity (CE)	<ul style="list-style-type: none"> <li>• Processor CE2T5323xx *)</li> <li>• Radio module CE2T5323xx01 *)</li> <li>• M-bus module CE2T5323xx02 *)</li> </ul>
Heating media quality	VDI guideline 2035
Type approval as per	EN 1434-4 Environment class A Measuring accuracy class 3
Product standards	DIN EN 1434-1 (heat meters)

<b>Environmental compatibility</b>
Product environmental declaration CE1E5323en*) contains data on environmental-compatible product design and assessment (RoHS compliance, compositions, packaging, environmental benefits and disposal)

<b>Dimensions</b>	
(W x H x D):	
<ul style="list-style-type: none"> <li>• Processor</li> <li>• Flow measuring section</li> </ul>	<ul style="list-style-type: none"> <li>• 101.5 x 78 mm</li> <li>• See "Dimensions"</li> </ul>

<b>Housing material</b>	
Processor	ABS + PC Display glass

<b>Housing color</b>	
Processor	RAL 9016

<b>Weight</b>		
Unit complete with accessories	0.6 m³/h:	971 g
	1.5 m³/h:	971 g
	2.5 m³/h:	1014 g

\*) The documents can be downloaded from <http://siemens.com/bt/download>.

**Screwed type meter**

Mounting length 80 mm

Mounting length 110 mm

Mounting length 130 mm

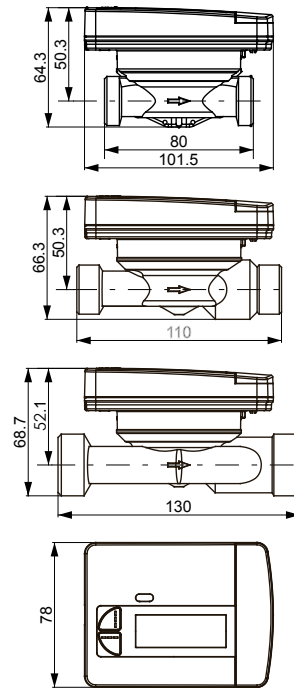

Dimensions in mm

**Add-on modules**

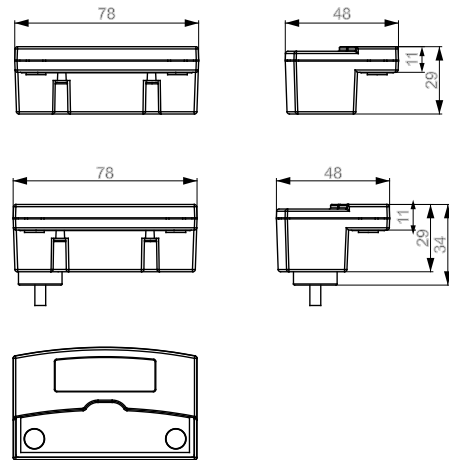

Dimensions in mm